

REVISIONS				
ZONE	REV	DESCRIPTION	DATE	APPROVED
	01	MADE TOL SYMMETRICAL	10/19/04	

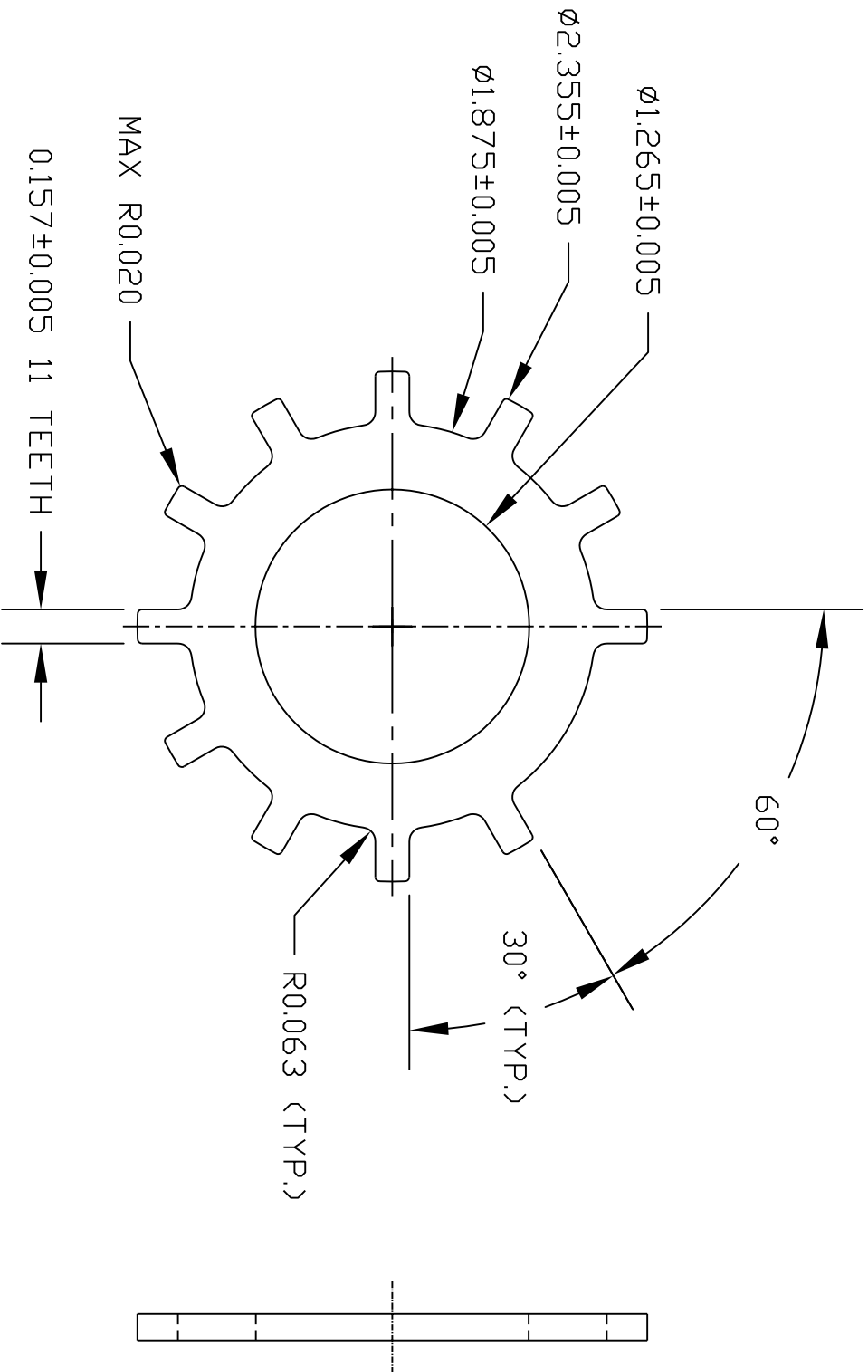

PERFORMANCE ELECTRONICS, LTD. (513) 777-5233		SIZE	DWG NO	DESC	REV
ALL TOL $\pm 0.010"$, $\pm 1"$ UNLESS STATED ALL DIMS IN INCHES		SCALE	236-126-TW	TRIGGER WHEEL, LARGE ID	01
			MATERIAL: C/D. R/D MILD STEEL 0.130" - 0.138" THICK	SHEET	