

Looking Into the Connector on the ECU

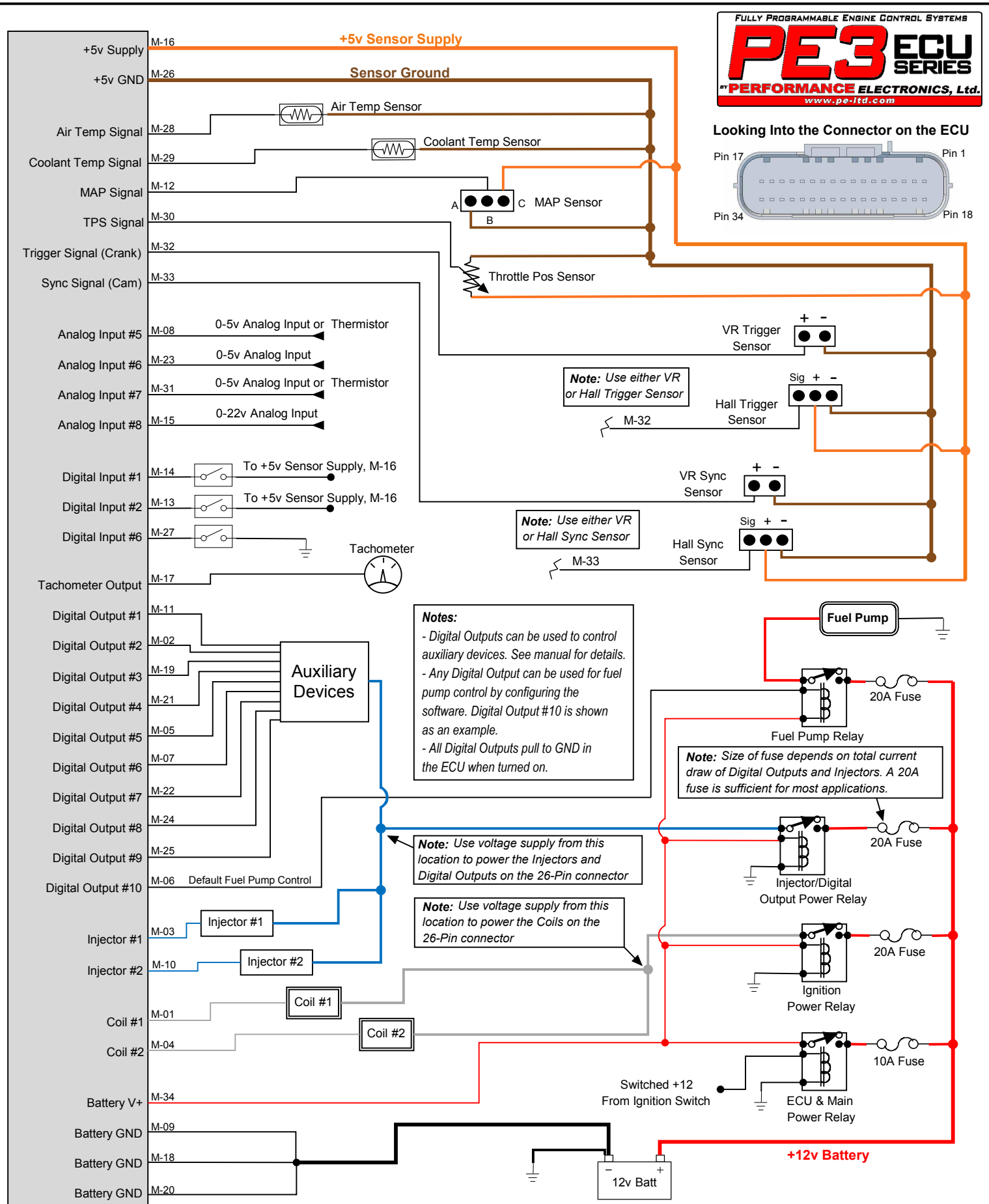
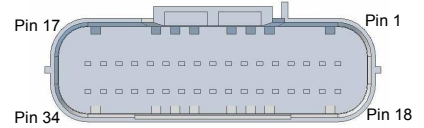

WIRING DIAGRAM

The **PE3** 34-Pin Main Connector

DRAWN BY

BL

DRAWING FILE

PE3 34P CN R4 10-29-11

