

Description	
Firmware/Software Version:	PE3 V3.03.02 and higher
Vehicle:	Any using one of the Bosch igniters listed
Additional Notes:	<p>Depending on which PE ECU is used, Bosch igniters may require an external pull-up resistor to be added by the user to the wire harness in order to drive the igniter and ignition coil(s).</p> <p>If using a PE3 ECU configured to drive 'smart coils' (i.e. PE3-8405) no external resistor is required.</p> <p>If using a PE3 ECU not configured for smart coils (i.e. PE3-8400), an external resistor for each coil is required.</p> <p>See wiring diagrams to the right.</p>

Configuration Details	
Trigger Mode:	External igniter. Must 'Enable External Coil Drivers' in the ignition tab of 'Setup Engine' in peMonitor.
Coil Charge Time:	Set based on specific ignition coil. The igniter does not control charge time.
Special Features:	May require an external pull-up resistor. See wiring diagram to the right.

Wiring Using Standard ECU (i.e. PE3-8400)

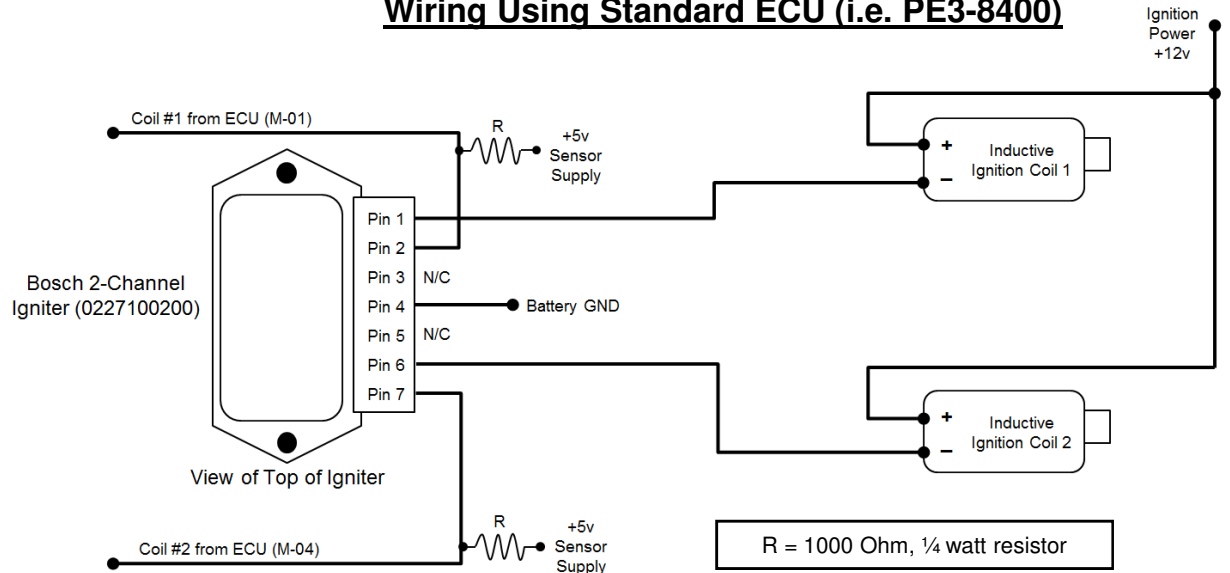

Wiring Using Smart Coil ECU (i.e. PE3-8405)

